

Kümi[®]

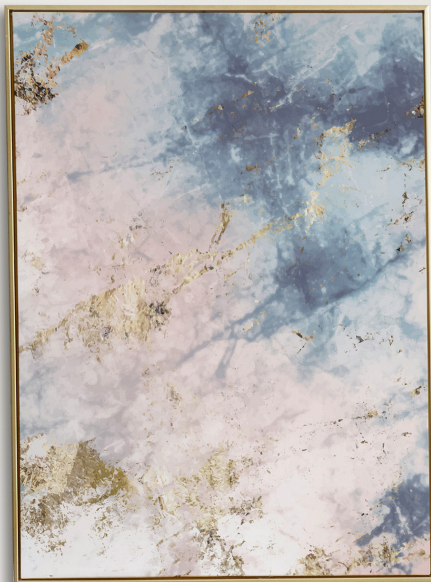

The Floring Collection

KUMI LOOKBOOK



Welcome to KUMI- a flooring collection designed

KUMI flooring is manufactured to LEED and FloorScore standards for superior indoor air quality and is fully certified to be free of Volatile Organic Compounds (VOC-free).

Volatile Organic Compounds (VOCs) are chemicals commonly found in building and finishing materials that are slowly released into the air we breathe. By choosing ARMADILLO flooring, you create a space where breathing is effortless and safe, knowing that harmful substances remain outside your home.

Diamond Technology-

Diamonds are a timeless symbol of beauty and longevity—and one of nature's hardest materials. Real diamonds are the key element in our **Diamond Technology Wear Layer**, delivering unmatched protection for your floors.

With a **double UV Fade coating**, our product is **flame, stain, scratch, and indent resistant**—keeping your floor looking as flawless as the day it was installed.



Diamond
Technology

IXPE PAD

Each ARMADILLO plank features an IXPE underlayment — an advanced cross-linked foam material that delivers:

- Excellent insulation,
- Walking comfort,
- Enhanced moisture protection,
- Resistance to mold and bacteria.
- 100% Waterproof

The pad comes pre-attached, speeding up installation and making the surface softer and quieter.



CLICK LOCK SYSTEM

Co-developed with pro installers and tooling engineers, our refined click profile—optimized for angle, depth, and bite—snaps in with less force and holds tighter under load, raising the bar for fit, speed, and reliability.

- Optimized click profile refined with pros
- Precise engagement angle, low-force snap
- Longer/thicker latch for stronger seams
- Faster installs with fewer taps & tools

Kümi

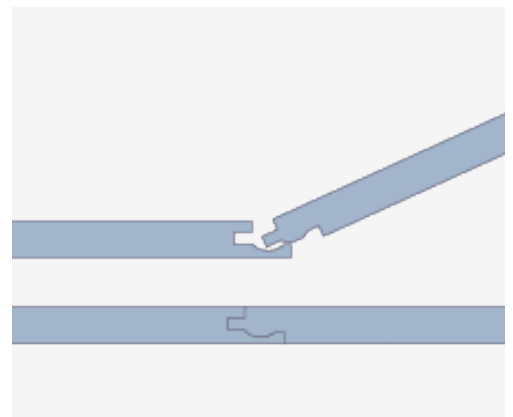



Chestnut Oak

Kümi



English Oak

Kümi



WILLOW OAK



SILVER MAPLE



CHESTNUT OAK



ENGLISH OAK



Anti-microbial



Fire Resistance



Waterproof



Indent Resistance



to be free of VOC's



Pet Friendly



Diamond
Technology



Light Commercial
Use



Willow Oak





Willow Oak

Kümi



Silver Maple

Kümi

ACCESSORIES & MOLDINGS

STAIR TREAD

One-piece vinyl stair tread — durable, waterproof

Pre-attached nosing for faster front installation

Adjustable end cap (left / right / open / wide) for a tailored fit

Kid- & pet-friendly

Scratch-resistant surface

Easy to clean and maintain

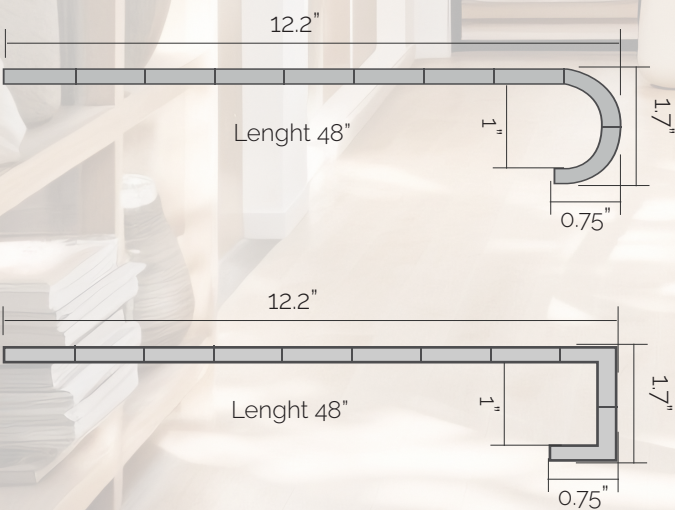

ARMADILLO
FLOORING



3-IN-1 UNIVERSAL TRIM

One profile, three functions—reducer, T-molding, and end cap—for clean transitions between different rooms and floor heights.

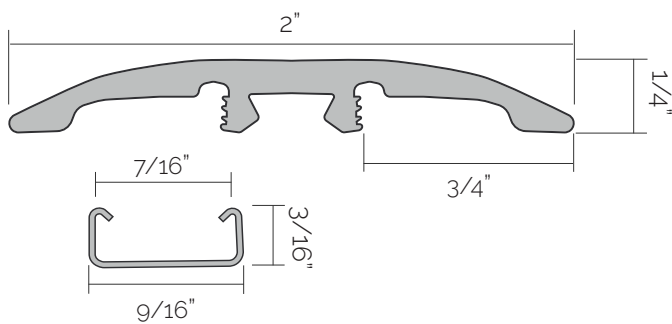

FLUSH STAIR NOSE

Low-profile stair edge that finishes step-downs with a smooth, continuous line. Engineered to pair with click-lock planks for a tight, safe fit.

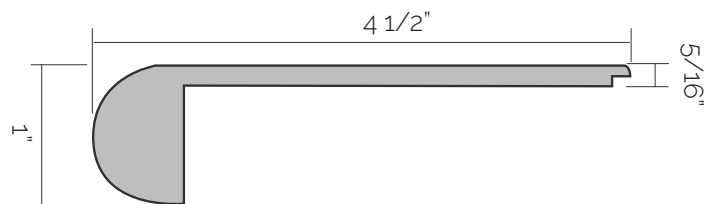



PRODUCT SPECIFICATIONS

PRODUCT

SKU/Color Names :

- AT-02 Chestnut Oak
- AT-03 English Oak
- AT-04 Silver Maple
- AT-05 Willow Oak

Construction :

- 4mm Rigid Core (Stone and Virgin DOTP Composite)
- 1mm IXPE attached cushion (No VOCs)
- 5 unique planks per pattern, 10 with a flip

Wear Layer :

22mil with Diamond Technology Finish (Proposition 65 Compliant)

Installation :

- Click, Unilin Locking System
- Float or Glue Down
- 50 LF before transition needed
- Matching Accessories: 3-in-1 Molding, Flush Stair Nose
- Use Polyurethane for wet spaces. Pressure sensitive adhesive is acceptable for other areas. Please reference our installation instructions for further details or contact kevin.n@unifiedinteriors.biz

* A 50'x50' install requires 10mm expansion space along walls in uncontrolled environments (such as no HVAC).
 * Do not install below 50°F, 24-hr acclimation time.
 * Use a floor mat for furniture utilizing castor wheels

SIZE/PACKAGING

Plank Size : 7.2" x 48"	
Planks/Carton : 10	Sq. Ft./Carton : 24.028
Cartons/Pallet : 55	Sq. Ft./Pallet : 1321.54
Sq. Ft./Container : 26,430.80	

FEATURES

 Anti-microbial	 Indent Resistance	 Fire Resistance	 Pet Friendly	 Waterproof
---	--	--	---	---

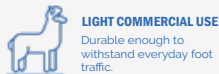

TEST DATA

ASTM E492-09 Impact Sound Conduction & ASTM E90-09 Airborne Sound Conduction	6"slab, no drop ceiling: STC 53 db / IIC 55 db OSB subfloor with fiberglass and open truss using standard resilient channel with fastened gypsum board: STC 58 / IIC 55 / IIC 66
* Sound test scores are relative to varying conditions. For accurate results, contact Durato for on-site testing and/or specific buildouts.	
ASTM D2394 Slip Resistance DCOF (Sliding)	Wet: Manufacturing Direction 0.63 Wet: Across-Manufacturing Direction 0.72 Dry: Manufacturing Direction 0.58 Dry: Across-Manufacturing Direction 0.60
ASTM D2394 Slip Resistance SCOF (Static)	Wet: Manufacturing Direction 0.72 Wet: Across-Manufacturing Direction 0.88 Dry: Manufacturing Direction 0.59 Dry: Across-Manufacturing Direction 0.70
ASTM D1037 Dynamic Load Limit	1,162 psi
ASTM F970-22 Static Load Limit	Passes, 0.35mm indent, 250 psi
ASTM F1914-18 Residual Indentation	Meets or Exceeds, average 0.09mm
ASTM F2199-20 Dimensional Stability	Meets or Exceeds
ASTM E648 Critical Radiant Flux	Meets or Exceeds, Class 1 (>1.10)
ASTM F1514-19 Resistance to Heat	Meets or Exceeds, average ΔE' 0.80
ASTM F1515-21 Resistance to Light	Meets or Exceeds, average ΔE' 1.72
ASTM F925-13 Resistance to Chemicals	No change, Not affected
ASTM C518 Thermal Resistance	R Value -0.6

WARRANTY



KUMI
925 Pennsylvania Blvd.
Feasterville-Treose, PA 19053

Tel: 267 309 0995
kevin.n@unifiedinteriors.biz





Kümi[®]

KUMI

925 Pennsylvania Blvd.
Feasterville-Treose, PA 19053

Tel: 267 309 0995
kevin.n@unifiedinteriors.biz

